

INSTALLATION GUIDE



Maestro SW



Infiniti G35 2006
All



Alpine INE-W977HD
Wired Remote Input

VEHICLE WIRING DIAGRAM

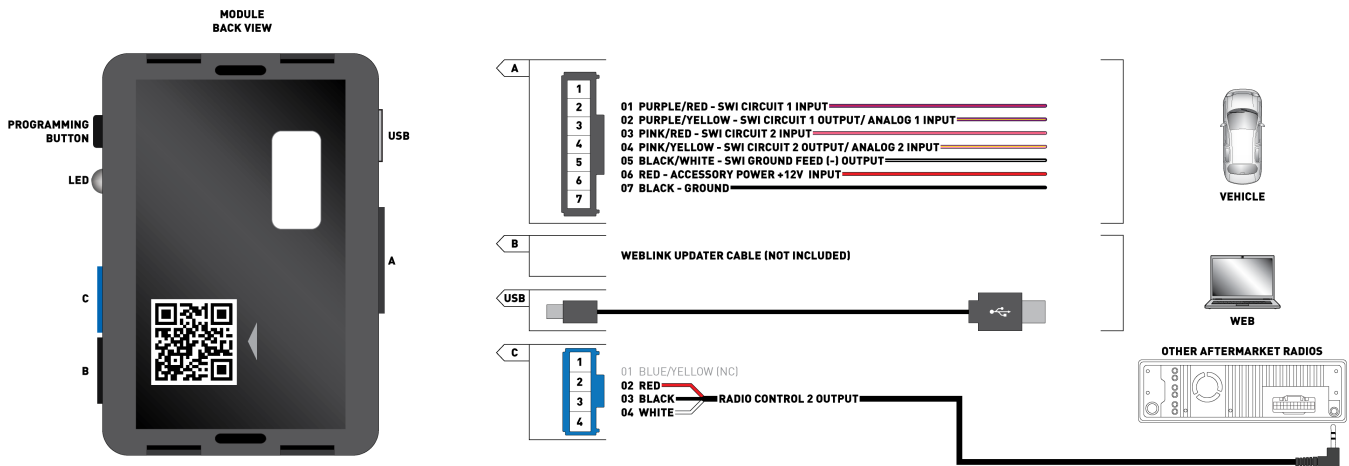

MODULES WIRES

VEHICLE WIRES

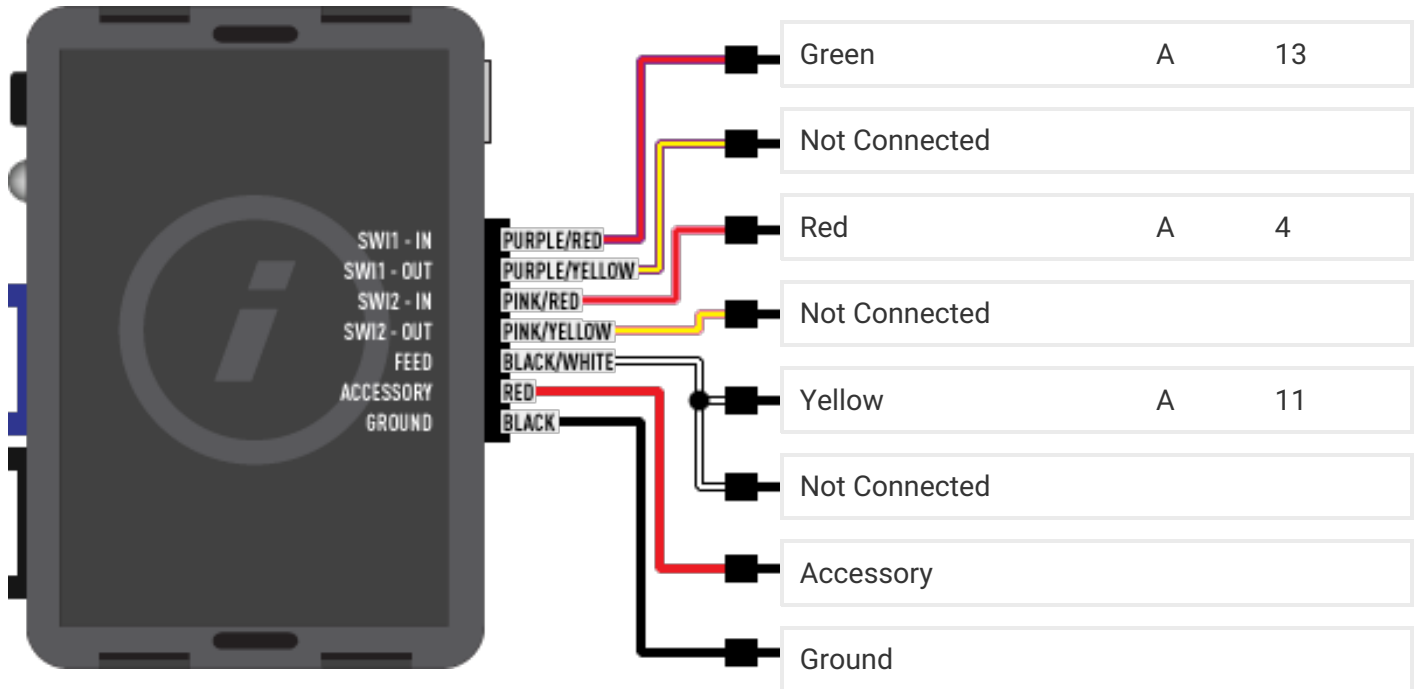

CONNECTORS

Connector A (16 pins)

Location: Radio

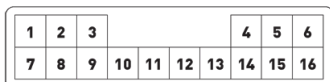

BLUETOOTH MODULE MUST BE BYPASSED

In order to use the steering wheel buttons you must bypass the Bluetooth module located under right side of package shelf. Connect pin 12 to pin 17, connect pin 13 to pin 18, connect pin 14 to pin 19. Leave the Bluetooth connector disconnected. Connector drawing is viewed from pin side.

