

CAMSHAFT

5. Tighten camshaft bracket bolts in the following steps, in numerical order as shown in the figure.
 - a. Tighten No. 7 to 10, then tighten No. 1 to 6 in order as shown.

: 1.96 N·m (0.2 kg-m, 17 in-lb)

- b. Tighten all bolts in numerical order as shown.

: 5.88 N·m (0.6 kg-m, 52 in-lb)

- c. Tighten No. 1 to 6 in numerical order as shown.

: 9.02 - 11.8 N·m (0.92 - 1.20 kg-m, 80 - 104 in-lb)

- d. Tighten No. 7 to 10 in numerical order as shown.

: 8.3 - 10.3 N·m (0.85 - 1.0 kg-m, 74 - 91 in-lb)

CAUTION:

After tightening mounting bolts of camshaft brackets (No. 1), be sure to wipe off excessive liquid gasket from the parts list below.

- Mating surface of rocker cover
- Mating surface of rear timing chain case

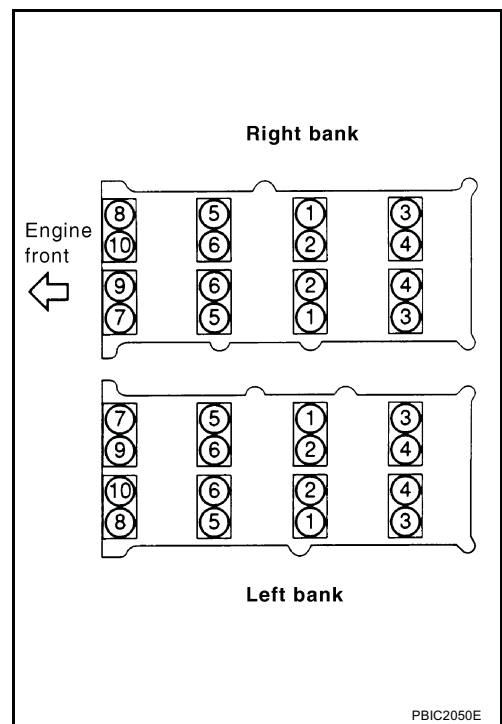

6. Measure the difference in levels between front end faces of camshaft bracket (No. 1) and cylinder head.

Standard : -0.14 to 0.14 mm (-0.0055 to 0.0055 in)

- If measured value is out of the standard, re-install camshaft bracket (No. 1).

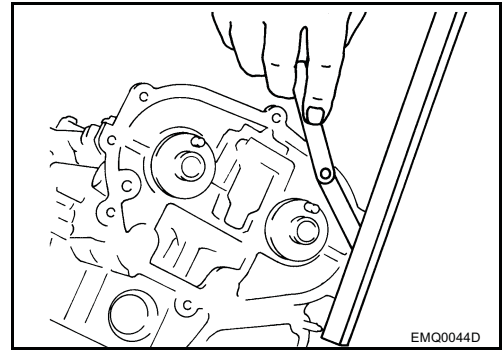

7. Check and adjust valve clearance. Refer to [EM-91. "Valve Clearance"](#).
8. Install in the reverse order of removal after this step.

Valve Clearance INSPECTION

Perform inspection as follows after removal, installation or replacement of camshaft or valve-related parts, or if there is unusual engine conditions regarding valve clearance.

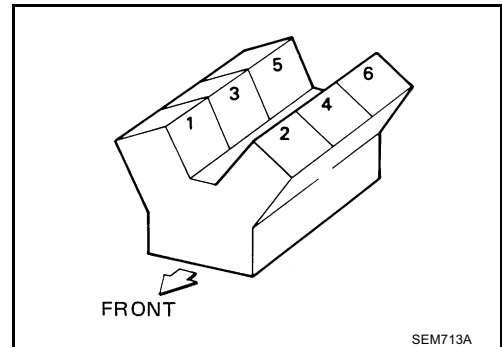

1. Remove rocker covers (right and left banks) with power tool. Refer to [EM-52. "ROCKER COVER"](#).
2. Measure the valve clearance as follows:
 - a. Set No.1 cylinder at TDC of its compression stroke.

CAMSHAFT

- Rotate crankshaft pulley clockwise to align timing mark (grooved line without color) with timing indicator.

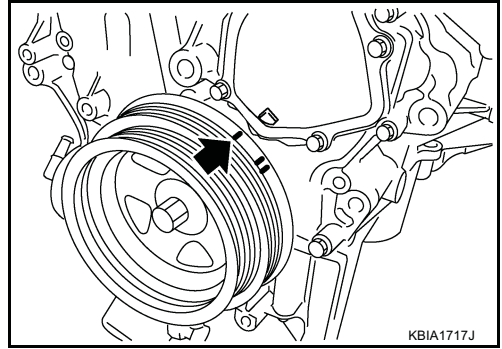

- Make sure that intake and exhaust cam nose on No. 1 cylinder (engine front side of right bank) are located as shown in the figure.
- If not, turn crankshaft one revolution (360 degrees) and align as shown in the figure.

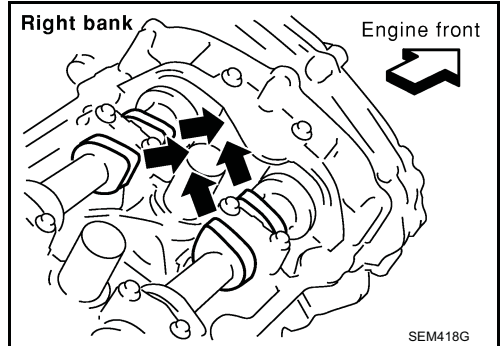

b. Measure the valve clearance with feeler gauge.

Valve clearance standard:

Cold	Intake	: 0.26 - 0.34 mm (0.010 - 0.013 in)
	Exhaust	: 0.29 - 0.37 mm (0.011 - 0.015 in)
Hot*	Intake	: 0.304 - 0.416 mm (0.012 - 0.016 in)
	Exhaust	: 0.308 - 0.432 mm (0.012 - 0.017 in)

*: Approximately 80°C (176°F) (Reference data)

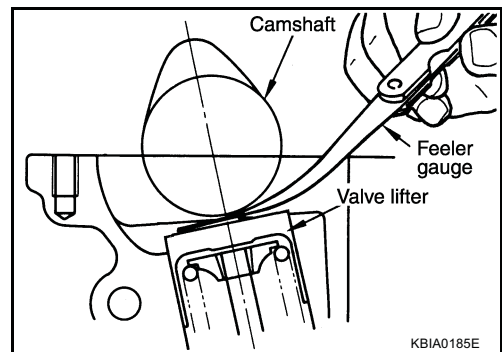
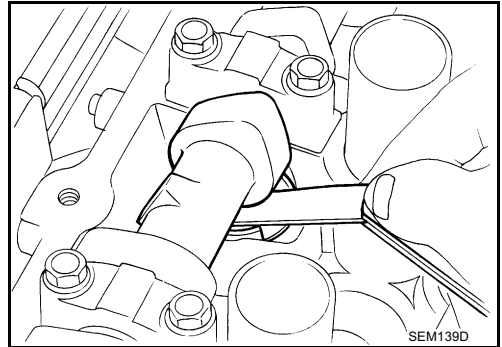

CAMSHAFT

● No.1 cylinder at compression TDC

Measuring position (right bank)		No. 1 CYL.	No. 3 CYL.	No. 5 CYL.
No. 1 cylinder at TDC	EXH		×	
	INT	×		
Measuring position (left bank)		No. 2 CYL.	No. 4 CYL.	No. 6 CYL.
No. 1 cylinder at TDC	INT			×
	EXH	×		

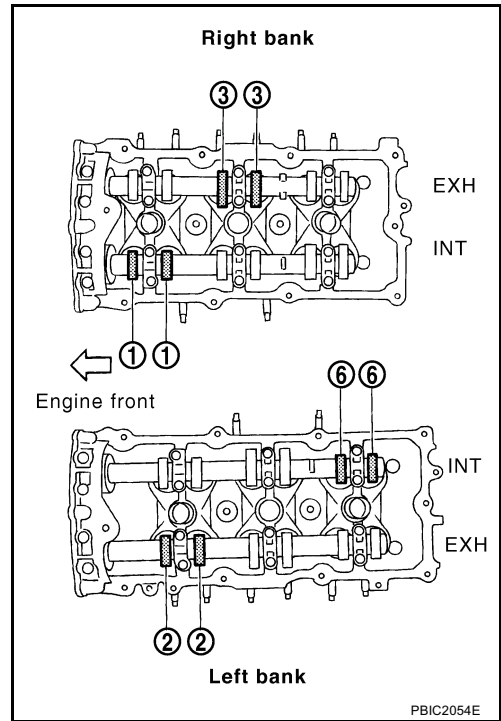

A
EM
C
D
E
F
G
H
I
J
K
L
M

- c. Rotate crankshaft by 240 degrees clockwise (when viewed from engine front) to align No. 3 cylinder at TDC of its compression stroke.

NOTE:

Crankshaft pulley mounting bolt flange has a stamped line every 60 degrees. They can be used as a guide to rotation angle.

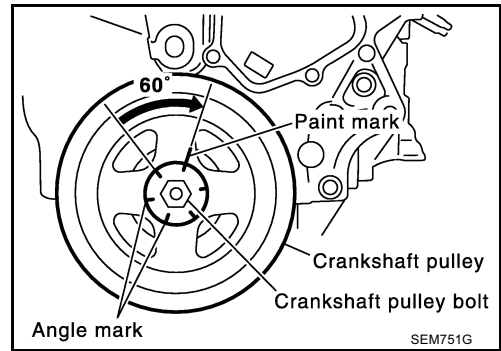

● No. 3 cylinder at compression TDC

Measuring position (right bank)		No. 1 CYL.	No. 3 CYL.	No. 5 CYL.
No. 3 cylinder at TDC	EXH			×
	INT		×	
Measuring position (left bank)		No. 2 CYL.	No. 4 CYL.	No. 6 CYL.
No. 3 cylinder at TDC	INT	×		
	EXH		×	

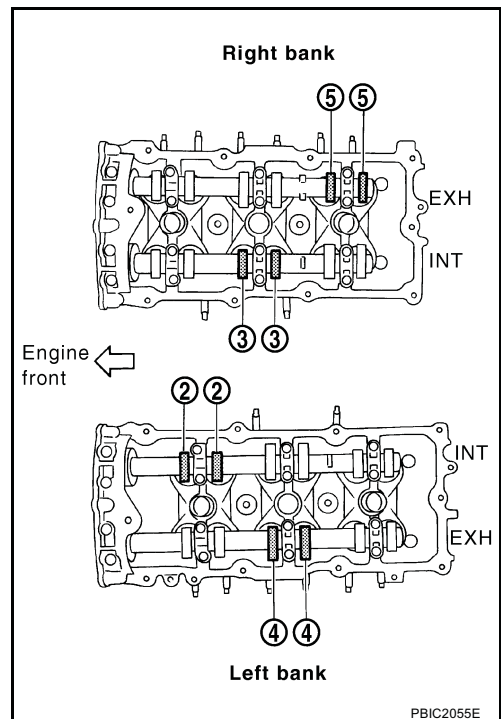

CAMSHAFT

- d. Rotate crankshaft by 240 degrees clockwise (when viewed from engine front) to align No. 5 cylinder at TDC of compression stroke.

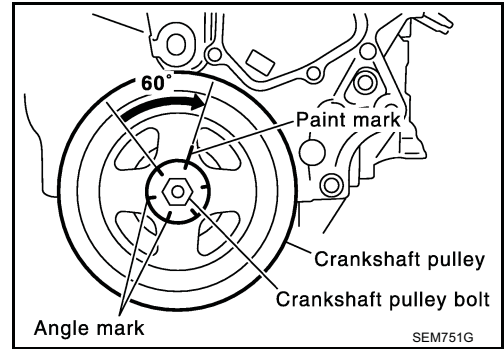

- No. 5 cylinder at compression TDC

Measuring position (right bank)		No. 1 CYL.	No. 3 CYL.	No. 5 CYL.
No. 5 cylinder at TDC	EXH	×		
	INT			×
Measuring position (left bank)		No. 2 CYL.	No. 4 CYL.	No. 6 CYL.
No. 5 cylinder at TDC	INT		×	
	EXH			×

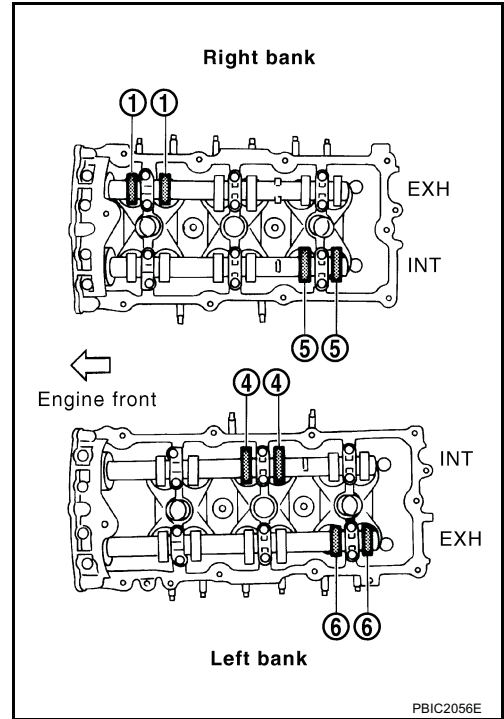

3. For measured value are out of the standard, perform adjustment. Refer to [EM-94. "ADJUSTMENT"](#) .

ADJUSTMENT

- Perform adjustment depending on selected head thickness of valve lifter.
1. Remove camshaft. Refer to [EM-85. "REMOVAL"](#) .
 2. Remove valve lifters at the locations that are out of the standard.
 3. Measure the center thickness of removed valve lifters with micrometer.

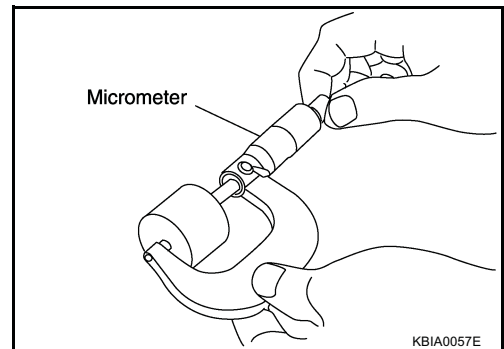

4. Use the equation below to calculate valve lifter thickness for replacement.

Valve lifter thickness calculation: $t = t_1 + (C_1 - C_2)$

t = Valve lifter thickness to be replaced

t₁ = Removed valve lifter thickness

CAMSHAFT

C1 = Measured valve clearance

C2 = Standard valve clearance:

Intake : 0.30 mm (0.012 in)*

Exhaust : 0.33 mm (0.013 in)*

***: Approximately 20°C (68°F)**

- Thickness of new valve lifter can be identified by stamp marks on the reverse side (inside the cylinder). Stamp mark 788U or 788R indicates 7.88 mm (0.3102 in) in thickness.

NOTE:

2 types of stamp marks are used for parallel setting and for manufacturer identification.

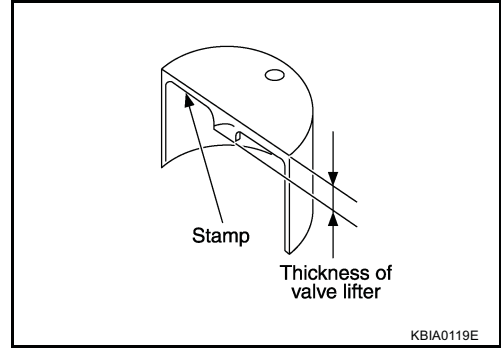

Available thickness of valve lifter: 27 sizes with range 7.88 to 8.40 mm (0.3102 to 0.3307 in) in steps of 0.02 mm (0.0008 in) (when manufactured at factory). Refer to [EM-153, "Available Valve Lifter"](#) .

5. Install selected valve lifter.
6. Install camshaft. Refer to [EM-89, "INSTALLATION"](#) .
7. Manually turn crankshaft pulley a few turns.
8. Make sure that valve clearances for cold engine are within specifications by referring to the specified values.

Valve clearance:

Unit: mm (in)

	Cold	Hot * (reference data)
Intake	0.26 - 0.34 (0.010 - 0.013)	0.304 - 0.416 (0.012 - 0.016)
Exhaust	0.29 - 0.37 (0.011 - 0.015)	0.308 - 0.432 (0.012 - 0.017)

*: Approximately 80°C (176°F)