

DTC P1217 ENGINE OVER TEMPERATURE

DTC P1217 ENGINE OVER TEMPERATURE

PF0:0000

Description SYSTEM DESCRIPTION

ABS00E12

NOTE:

If DTC P1217 is displayed with DTC U1000 or U1001, first perform the trouble diagnosis for DTC U1000, U1001. Refer to [EC-164, "DTC U1000, U1001 CAN COMMUNICATION LINE"](#).

Cooling Fan Control

Sensor	Input Signal to ECM	ECM function	Actuator
Crankshaft position sensor (POS) Camshaft position sensor (PHASE)	Engine speed*1	Cooling fan control	IPDM E/R (Cooling fan relay)
Battery	Battery voltage*1		
Wheel sensor	Vehicle speed*2		
Engine coolant temperature sensor	Engine coolant temperature		
Air conditioner switch	Air conditioner ON signal*2		
Refrigerant pressure sensor	Refrigerant pressure		

*1: The ECM determines the start signal status by the signals of engine speed and battery voltage.

*2: This signal is sent to ECM through CAN communication line.

The ECM controls the cooling fan corresponding to the vehicle speed, engine coolant temperature, refrigerant pressure, and air conditioner ON signal. The control system has 3-step control [HIGH/LOW/OFF].

Cooling Fan Operation

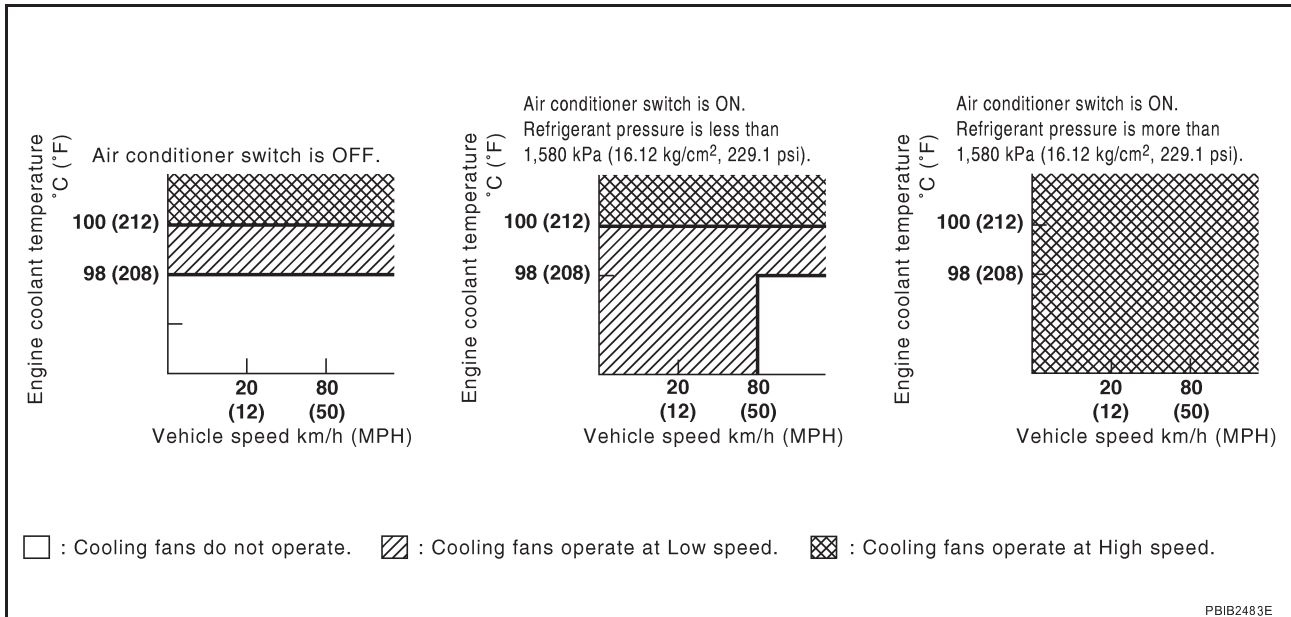

DTC P1217 ENGINE OVER TEMPERATURE

Cooling Fan Relay Operation

The ECM controls cooling fan relays in the IPDM E/R through CAN communication line.

Cooling fan speed	Cooling fan relay		
	1	2	3
Stop	OFF	OFF	OFF
Low	ON	OFF	OFF
High	ON	ON	ON

COMPONENT DESCRIPTION

Cooling Fan Motor

The cooling fan operates at each speed when the current flows in the cooling fan motor as follows.

Cooling fan speed	Cooling fan motor terminals	
	(+)	(-)
Low	1	4
	2	3
High	1 and 2	3 and 4

CONSULT-II Reference Value in Data Monitor Mode

ABS00E13

Specification data are reference values.

MONITOR ITEM	CONDITION	SPECIFICATION	
AIR COND SIG	<ul style="list-style-type: none"> Engine: After warming up, idle the engine 	Air conditioner switch: OFF	OFF
		Air conditioner switch: ON (Compressor operates.)	ON
COOLING FAN	<ul style="list-style-type: none"> Engine: After warming up, idle the engine Air conditioner switch: OFF 	Engine coolant temperature is 97°C (206°F) or less	OFF
		Engine coolant temperature is between 98°C (208°F) and 99°C (210°F)	LOW
		Engine coolant temperature is 100°C (212°F) or more	HI

On Board Diagnosis Logic

ABS00E14

If the cooling fan or another component in the cooling system malfunctions, engine coolant temperature will rise.

When the engine coolant temperature reaches an abnormally high temperature condition, a malfunction is indicated.

This self-diagnosis has the one trip detection logic.

DTC No.	Trouble diagnosis name	DTC detecting condition	Possible cause
P1217 1217	Engine over temperature (Overheat)	<ul style="list-style-type: none"> Cooling fan does not operate properly (Overheat). Cooling fan system does not operate properly (Overheat). Engine coolant was not added to the system using the proper filling method. Engine coolant is not within the specified range. 	<ul style="list-style-type: none"> Harness or connectors (The cooling fan circuit is open or shorted.) Cooling fan IPDM E/R (Cooling fan relays) Radiator hose Radiator Radiator cap Water pump Thermostat <p>For more information, refer to EC-465, "Main 12 Causes of Overheating".</p>

DTC P1217 ENGINE OVER TEMPERATURE

CAUTION:

When a malfunction is indicated, be sure to replace the coolant. Refer to [MA-12, "Changing Engine Coolant"](#) . Also, replace the engine oil. Refer to [MA-15, "Changing Engine Oil"](#) .

1. Fill radiator with coolant up to specified level with a filling speed of 2 liters per minute. Be sure to use coolant with the proper mixture ratio. Refer to [MA-10, "Anti-Freeze Coolant Mixture Ratio"](#) .
2. After refilling coolant, run engine to ensure that no water-flow noise is emitted.

Overall Function Check

ABS00E15

Use this procedure to check the overall function of the cooling fan. During this check, a DTC might not be confirmed.

WARNING:

Never remove the radiator cap when the engine is hot. Serious burns could be caused by high pressure fluid escaping from the radiator.

Wrap a thick cloth around cap. Carefully remove the cap by turning it a quarter turn to allow built-up pressure to escape. Then turn the cap all the way off.

WITH CONSULT-II

1. Check the coolant level in the reservoir tank and radiator.
Allow engine to cool before checking coolant level.
If the coolant level in the reservoir tank and/or radiator is below the proper range, skip the following steps and go to [EC-460, "Diagnostic Procedure"](#) .
2. Confirm whether customer filled the coolant or not. If customer filled the coolant, skip the following steps and go to [EC-460, "Diagnostic Procedure"](#) .
3. Turn ignition switch ON.
4. Perform "COOLING FAN" in "ACTIVE TEST" mode with CONSULT-II.
5. If the results are NG, go to [EC-460, "Diagnostic Procedure"](#) .

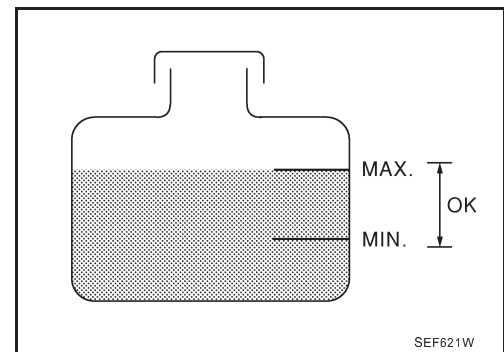

ACTIVE TEST	
COOLING FAN	OFF
MONITOR	
COOLAN TEMP/S	XXX °C

SEF646X

WITH GST

1. Check the coolant level in the reservoir tank and radiator.
Allow engine to cool before checking coolant level.
If the coolant level in the reservoir tank and/or radiator is below the proper range, skip the following steps and go to [EC-460, "Diagnostic Procedure"](#) .
2. Confirm whether customer filled the coolant or not. If customer filled the coolant, skip the following steps and go to [EC-460, "Diagnostic Procedure"](#) .
3. Start engine.
CAUTION:
Be careful not to overheat engine.
4. Turn air conditioner switch ON.
5. Turn blower fan switch ON.

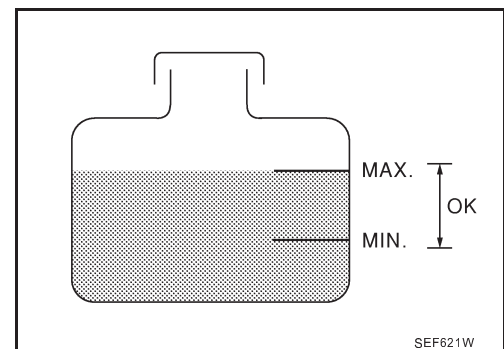

DTC P1217 ENGINE OVER TEMPERATURE

6. Make sure that cooling fan operates at low speed.
If NG, go to [EC-460, "Diagnostic Procedure"](#) .
If OK, go to the following step.
7. Turn ignition switch OFF.
8. Turn air conditioner switch and blower fan switch OFF.
9. Disconnect engine coolant temperature sensor harness connector.
10. Connect 150Ω resistor to engine coolant temperature sensor harness connector.

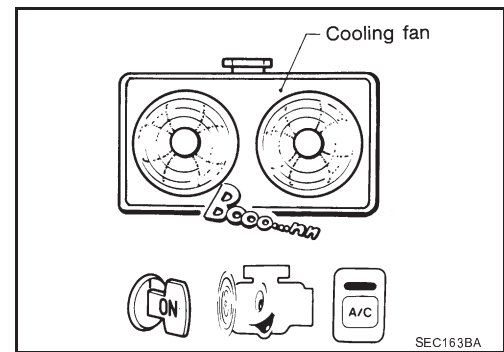

11. Restart engine and make sure that cooling fan operates at higher speed than low speed.

CAUTION:

Be careful not to overheat engine.

12. If NG, go to [EC-460, "Diagnostic Procedure"](#) .

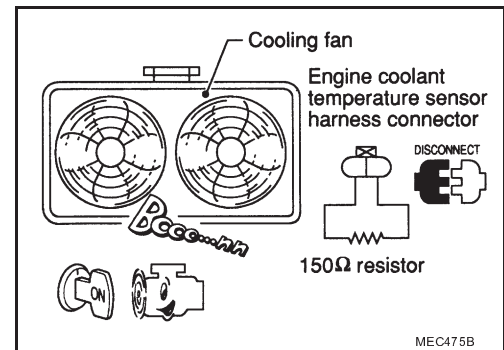

A

EC

C

D

E

F

G

H

I

J

K

L

M

DTC P1217 ENGINE OVER TEMPERATURE

ABS00E16

Wiring Diagram

EC-COOL/F-01

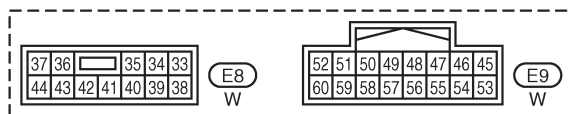
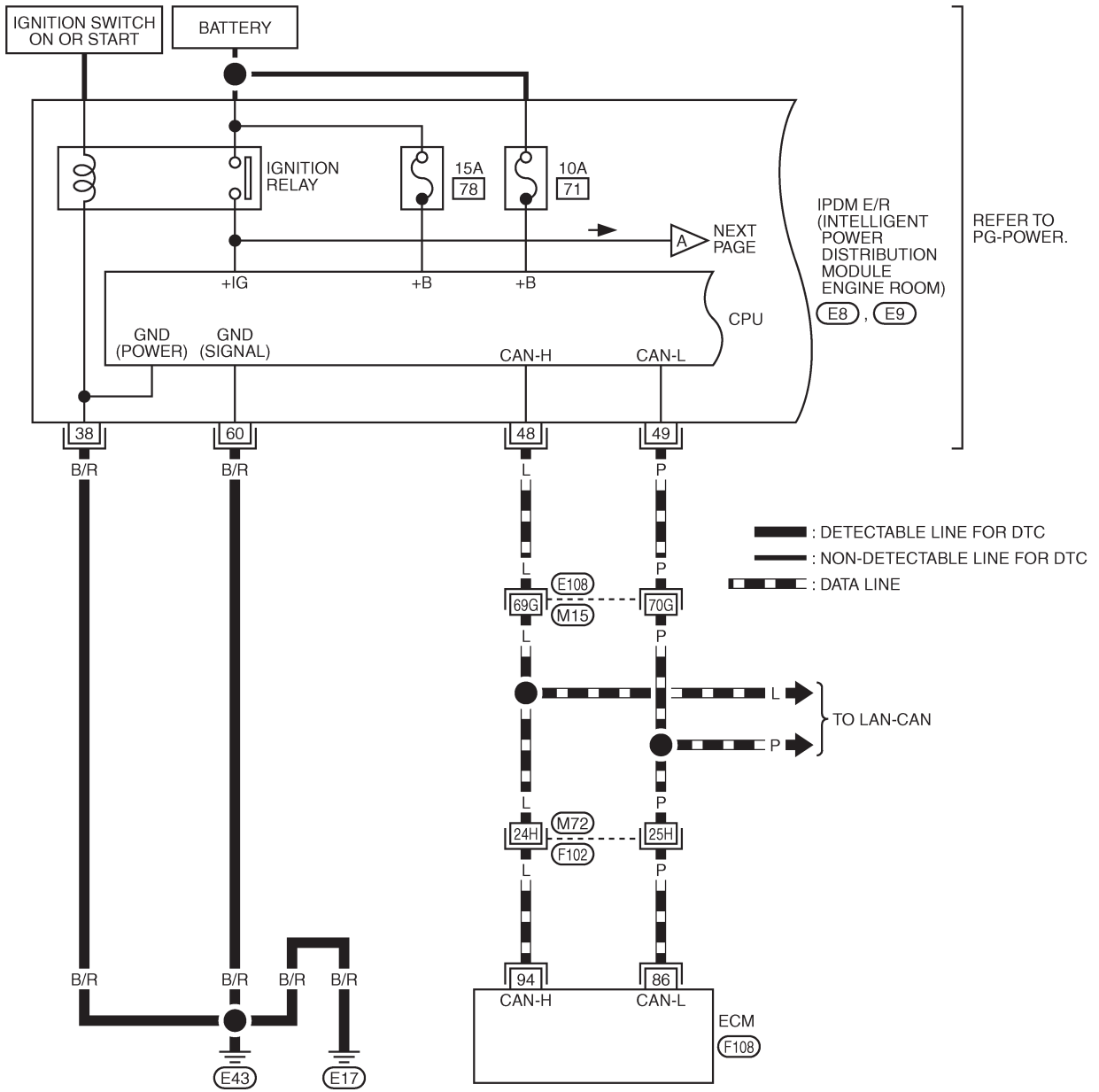

REFER TO THE FOLLOWING.
 (E108), (F102) -SUPER MULTIPLE JUNCTION (SMJ)

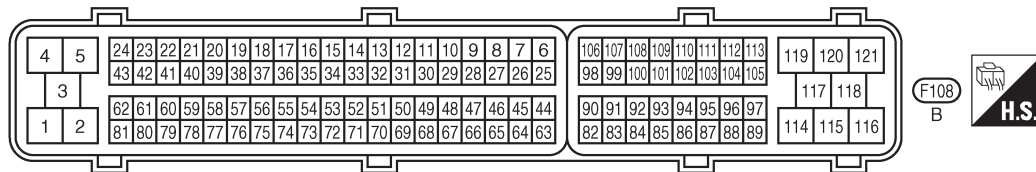

TBWM0822E

DTC P1217 ENGINE OVER TEMPERATURE

EC-COOL/F-02

— : DETECTABLE LINE FOR DTC
 - - - : NON-DETECTABLE LINE FOR DTC

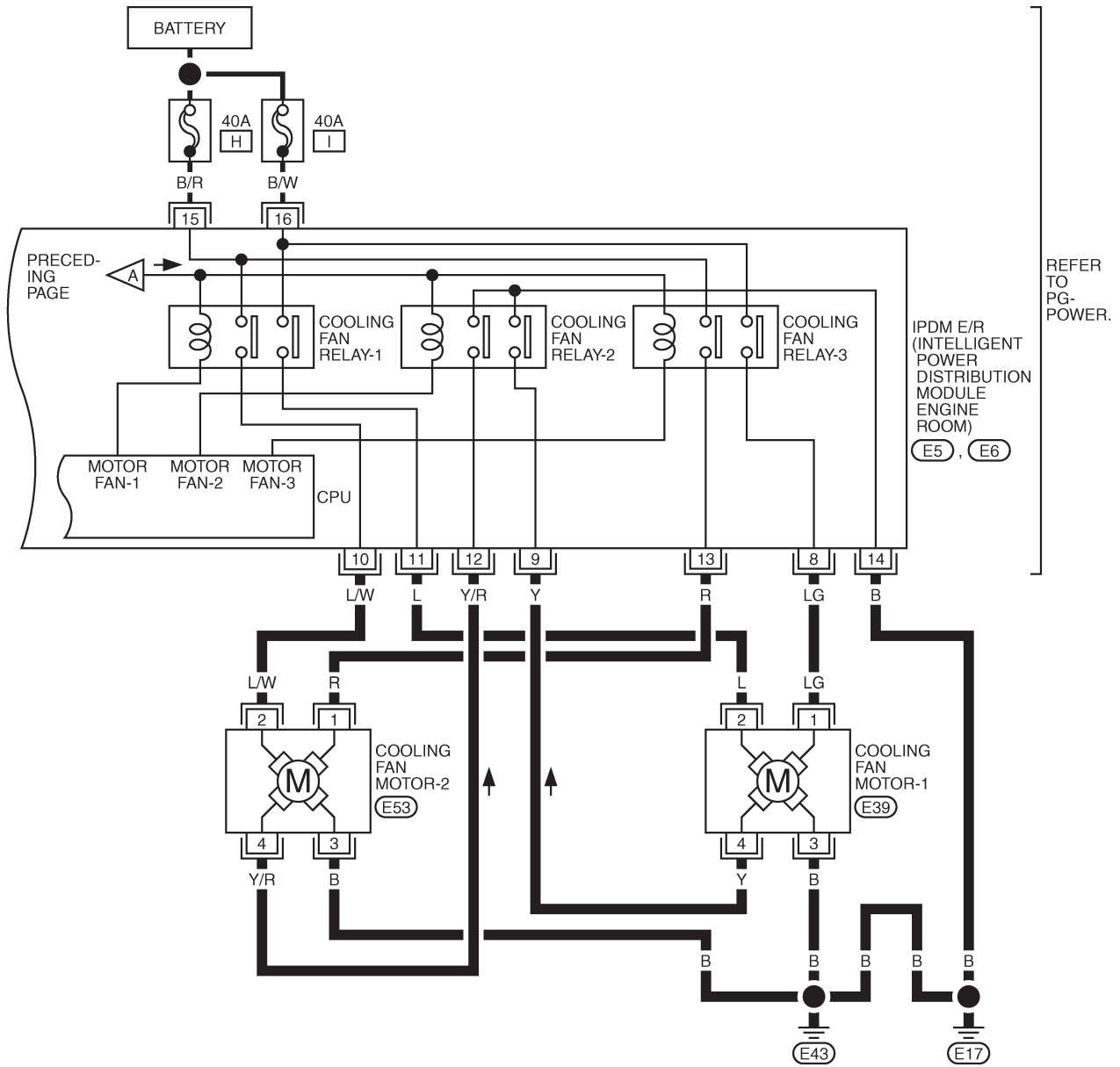

DTC P1217 ENGINE OVER TEMPERATURE

ABS00E17

Diagnostic Procedure

1. INSPECTION START

Do you have CONSULT-II?

Yes or No

- Yes >> GO TO 2.
- No >> GO TO 4.

2. CHECK COOLING FAN LOW SPEED OPERATION

With CONSULT-II

1. Start engine and let it idle.
2. Select "COOLING FAN" in "ACTIVE TEST" mode with CONSULT-II and touch "LOW" on the CONSULT-II screen.
3. Make sure that cooling fans-1 and -2 operate at low speed.

OK or NG

- OK >> GO TO 3.
- NG >> Check cooling fan low speed control circuit. (Go to [EC-462, "PROCEDURE A"](#).)

ACTIVE TEST	
COOLING FAN	LOW
MONITOR	
COOLAN TEMP/S	XXX °C

SEF784Z

3. CHECK COOLING FAN HIGH SPEED OPERATION

With CONSULT-II

1. Touch "HIGH" on the CONSULT-II screen.
2. Make sure that cooling fans-1 and -2 operate at higher speed than low speed.

OK or NG

- OK >> GO TO 6.
- NG >> Check cooling fan high speed control circuit. (Go to [EC-464, "PROCEDURE B"](#).)

ACTIVE TEST	
COOLING FAN	HIGH
MONITOR	
COOLAN TEMP/S	XXX °C

SEF785Z

4. CHECK COOLING FAN LOW SPEED OPERATION

Without CONSULT-II

1. Start engine and let it idle.
2. Turn air conditioner switch ON.
3. Turn blower fan switch ON.
4. Make sure that cooling fans-1 and -2 operate at low speed.

OK or NG

- OK >> GO TO 5.
- NG >> Check cooling fan low speed control circuit. (Go to [EC-462, "PROCEDURE A"](#).)

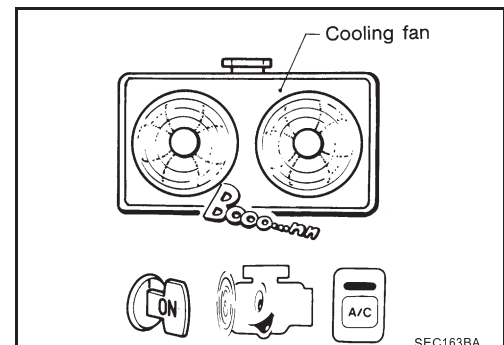

DTC P1217 ENGINE OVER TEMPERATURE

5. CHECK COOLING FAN HIGH SPEED OPERATION

⊗ Without CONSULT-II

1. Turn ignition switch OFF.
2. Turn air conditioner switch and blower fan switch OFF.
3. Disconnect engine coolant temperature sensor harness connector.
4. Connect 150Ω resistor to engine coolant temperature sensor harness connector.
5. Restart engine and make sure that cooling fans-1 and -2 operate at higher speed than low speed.

OK or NG

OK >> GO TO 6.

NG >> Check cooling fan high speed control circuit. (Go to [EC-464](#), "PROCEDURE B".)

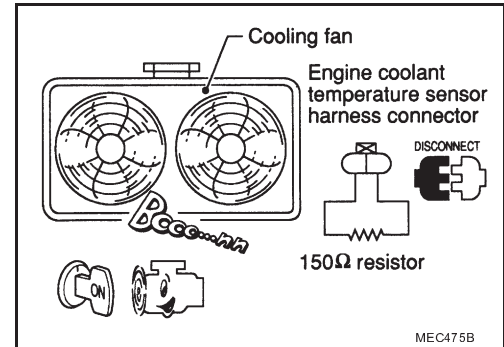

6. CHECK COOLING SYSTEM FOR LEAK

Apply pressure to the cooling system with a tester, and check if the pressure drops.

Testing pressure: 157 kPa (1.6 kg/cm² , 23 psi)

CAUTION:

Higher than the specified pressure may cause radiator damage. Pressure should not drop.

OK or NG

OK >> GO TO 7.

NG >> Check the following for leak. Refer to [CO-10](#), "LEAK CHECK".

- Hose
- Radiator
- Water pump

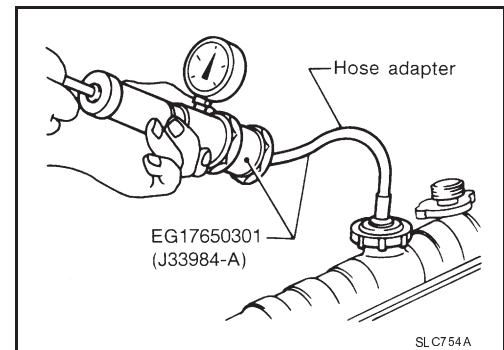

7. CHECK RADIATOR CAP

Apply pressure to cap with a tester.

Radiator cap relief pressure: 59 - 98 kPa (0.6 - 1.0 kg/cm² , 9 - 14 psi)

OK or NG

OK >> GO TO 8.

NG >> Replace radiator cap.

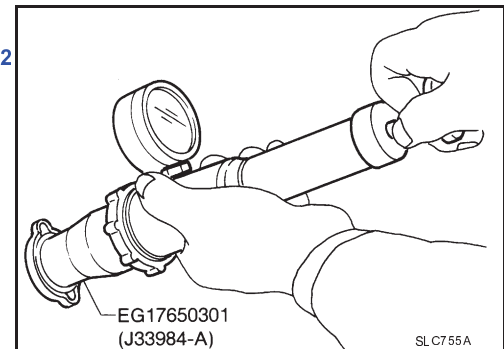

DTC P1217 ENGINE OVER TEMPERATURE

8. CHECK THERMOSTAT

1. Check valve seating condition at normal room temperatures.
It should seat tightly.
2. Check valve opening temperature and valve lift.

Valve opening temperature: 82°C (180°F) [standard]
Valve lift: More than 8.6 mm/95°C (0.339 in/203°F)

3. Check if valve is closed at 5°C (9°F) below valve opening temperature.
For details, refer to [CO-28, "WATER INLET AND THERMOSTAT ASSEMBLY"](#).

OK or NG

- OK >> GO TO 9.
NG >> Replace thermostat

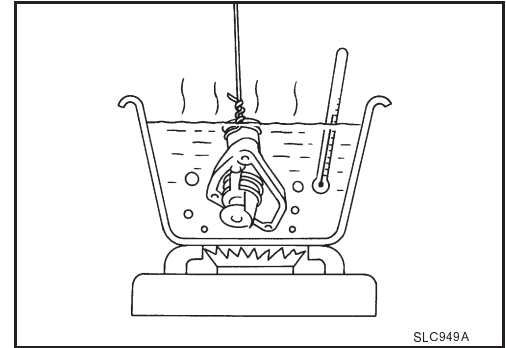

9. CHECK ENGINE COOLANT TEMPERATURE SENSOR

Refer to [EC-204, "Component Inspection"](#).

OK or NG

- OK >> GO TO 10.
NG >> Replace engine coolant temperature sensor.

10. CHECK MAIN 12 CAUSES

If the cause cannot be isolated, go to [EC-465, "Main 12 Causes of Overheating"](#).

>> INSPECTION END

PROCEDURE A

1. CHECK POWER SUPPLY CIRCUIT

1. Turn ignition switch OFF.
2. Disconnect IPDM E/R harness connector E6.
3. Check voltage between IPDM E/R terminals 15, 16 and ground with CONSULT-II or tester.

Voltage: Battery voltage

OK or NG

- OK >> GO TO 3.
NG >> GO TO 2.

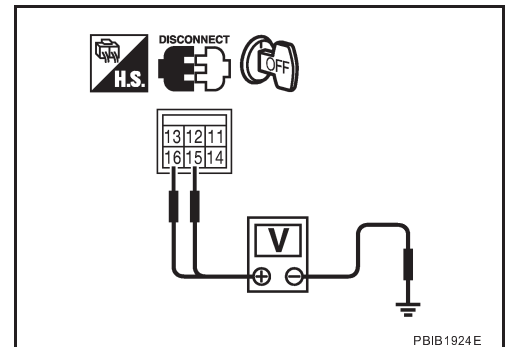

2. DETECT MALFUNCTIONING PART

Check the following.

- 40A fusible links
- Harness for open or short between IPDM E/R and battery

>> Repair open circuit or short to ground or short to power in harness or connectors.

DTC P1217 ENGINE OVER TEMPERATURE

3. CHECK COOLING FAN MOTORS CIRCUIT

1. Disconnect cooling fan motor-1 harness connector and cooling fan motor-2 harness connector.
2. Disconnect IPDM E/R harness connector E5.
3. Check harness continuity between the following;
cooling fan motor-1 terminal 2 and IPDM E/R terminal 11,
cooling fan motor-1 terminal 3 and ground.
IPDM E/R terminal 38, 60 and ground.
Refer to wiring diagram.

Continuity should exist.

4. Also check harness for short to ground and short to power.
5. Check harness continuity between the following;
cooling fan motor-2 terminal 2 and IPDM E/R terminal 10,
cooling fan motor-2 terminal 3 and ground.
Refer to wiring diagram.

Continuity should exist.

6. Also check harness for short to ground and short to power.

OK or NG

- OK >> GO TO 5.
- NG >> GO TO 4.

4. DETECT MALFUNCTIONING PART

Check the following.

- Harness for open or short between cooling fan motors-1, 2 and IPDM E/R
- Harness for open or short between cooling fan motors-1, 2 and ground
- Harness for open or short between IPDM E/R and ground

>> Repair open circuit or short to ground or short to power in harness connectors.

5. CHECK COOLING FAN MOTORS

Refer to [EC-465, "Component Inspection"](#) .

OK or NG

- OK >> GO TO 6.
- NG >> Replace cooling fan motors.

6. CHECK INTERMITTENT INCIDENT

Perform [EC-154, "TROUBLE DIAGNOSIS FOR INTERMITTENT INCIDENT"](#) .

OK or NG

- OK >> Replace IPDM E/R. Refer to [PG-17, "IPDM E/R \(INTELLIGENT POWER DISTRIBUTION MODULE ENGINE ROOM\)"](#) .
- NG >> Repair or replace harness or connector.

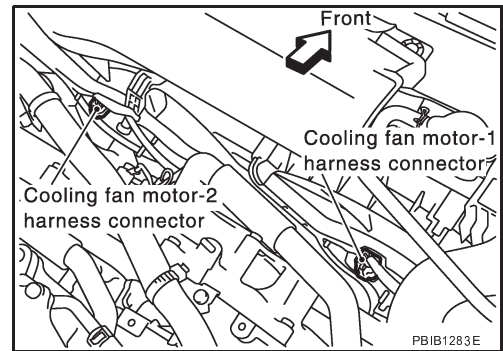

A

EC

C

D

E

F

G

H

I

J

K

L

M

DTC P1217 ENGINE OVER TEMPERATURE

PROCEDURE B

1. CHECK COOLING FAN MOTORS CIRCUIT

1. Turn ignition switch OFF.
2. Disconnect cooling fan motor-1 harness connector and cooling fan motor-2 harness connector.
3. Disconnect IPDM E/R harness connectors E5, E6.
4. Check harness continuity between the following; cooling fan motor-1 terminal 1 and IPDM E/R terminal 8, cooling fan motor-1 terminal 4 and IPDM E/R terminal 9, IPDM E/R terminal 14, 38, 60 and ground. Refer to wiring diagram.

Continuity should exist.

5. Also check harness for short to ground and short to power.
6. Check harness continuity between the following; cooling fan motor-2 terminal 1 and IPDM E/R terminal 13, cooling fan motor-2 terminal 4 and IPDM E/R terminal 12. Refer to wiring diagram.

Continuity should exist.

7. Also check harness for short to ground and short to power.

OK or NG

- OK >> GO TO 3.
- NG >> GO TO 2.

2. DETECT MALFUNCTIONING PART

Check the following.

- Harness for open or short between cooling fan motors-1, 2 and IPDM E/R
- Harness for open or short between cooling fan motors-1, 2 and ground
- Harness for open or short between IPDM E/R and ground

>> Repair open circuit or short to ground or short to power in harness connectors.

3. CHECK COOLING FAN MOTORS

Refer to [EC-465, "Component Inspection"](#) .

OK or NG

- OK >> GO TO 4.
- NG >> Replace cooling fan motors.

4. CHECK INTERMITTENT INCIDENT

Perform [EC-154, "TROUBLE DIAGNOSIS FOR INTERMITTENT INCIDENT"](#) .

OK or NG

- OK >> Replace IPDM E/R. Refer to [PG-17, "IPDM E/R \(INTELLIGENT POWER DISTRIBUTION MODULE ENGINE ROOM\)"](#) .
- NG >> Repair or replace harness connectors.

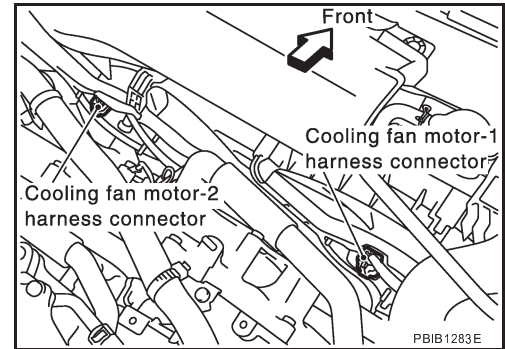

DTC P1217 ENGINE OVER TEMPERATURE

ABS00E18

Main 12 Causes of Overheating

Engine	Step	Inspection item	Equipment	Standard	Reference page
OFF	1	<ul style="list-style-type: none"> Blocked radiator Blocked condenser Blocked radiator grille Blocked bumper 	<ul style="list-style-type: none"> Visual 	No blocking	—
	2	<ul style="list-style-type: none"> Coolant mixture 	<ul style="list-style-type: none"> Coolant tester 	50 - 50% coolant mixture	MA-10, "Anti-Freeze Coolant Mixture Ratio"
	3	<ul style="list-style-type: none"> Coolant level 	<ul style="list-style-type: none"> Visual 	Coolant up to MAX level in reservoir tank and radiator filler neck	CO-10, "LEVEL CHECK"
	4	<ul style="list-style-type: none"> Radiator cap 	<ul style="list-style-type: none"> Pressure tester 	59 - 98 kPa (0.6 - 1.0 kg/cm ² , 9 - 14 psi) (Limit)	CO-15, "Checking Radiator Cap"
ON*2	5	<ul style="list-style-type: none"> Coolant leaks 	<ul style="list-style-type: none"> Visual 	No leaks	CO-10, "LEAK CHECK"
ON*2	6	<ul style="list-style-type: none"> Thermostat 	<ul style="list-style-type: none"> Touch the upper and lower radiator hoses 	Both hoses should be hot	CO-28, "WATER INLET AND THERMOSTAT ASSEMBLY"
ON*1	7	<ul style="list-style-type: none"> Cooling fan 	<ul style="list-style-type: none"> CONSULT-II 	Operating	See trouble diagnosis for DTC P1217 (EC-454).
OFF	8	<ul style="list-style-type: none"> Combustion gas leak 	<ul style="list-style-type: none"> Color checker chemical tester 4 Gas analyzer 	Negative	—
ON*3	9	<ul style="list-style-type: none"> Coolant temperature gauge 	<ul style="list-style-type: none"> Visual 	Gauge less than 3/4 when driving	—
		<ul style="list-style-type: none"> Coolant overflow to reservoir tank 	<ul style="list-style-type: none"> Visual 	No overflow during driving and idling	CO-10, "LEVEL CHECK"
OFF*4	10	<ul style="list-style-type: none"> Coolant return from reservoir tank to radiator 	<ul style="list-style-type: none"> Visual 	Should be initial level in reservoir tank	CO-10, "LEVEL CHECK"
OFF	11	<ul style="list-style-type: none"> Cylinder head 	<ul style="list-style-type: none"> Straight gauge feeler gauge 	0.1 mm (0.004 in) Maximum distortion (warping)	EM-92, "CYLINDER HEAD"
	12	<ul style="list-style-type: none"> Cylinder block and pistons 	<ul style="list-style-type: none"> Visual 	No scuffing on cylinder walls or piston	EM-110, "CYLINDER BLOCK"

*1: Turn the ignition switch ON.

*2: Engine running at 3,000 rpm for 10 minutes.

*3: Drive at 90 km/h (55 MPH) for 30 minutes and then let idle for 10 minutes.

*4: After 60 minutes of cool down time.

For more information, refer to [CO-6, "OVERHEATING CAUSE ANALYSIS"](#).

Component Inspection COOLING FAN MOTORS-1 AND -2

ABS00E19

- Disconnect cooling fan motor harness connectors.
- Supply cooling fan motor terminals with battery voltage and check operation.

	Speed	terminals	
		(+)	(-)
Cooling fan motor	Low	1	4
		2	3
	High	1 and 2	3 and 4

Cooling fan motor should operate.

If NG, replace cooling fan motor.

