

12. Inserting M5 J-nut ⑤ into the splash guard hole

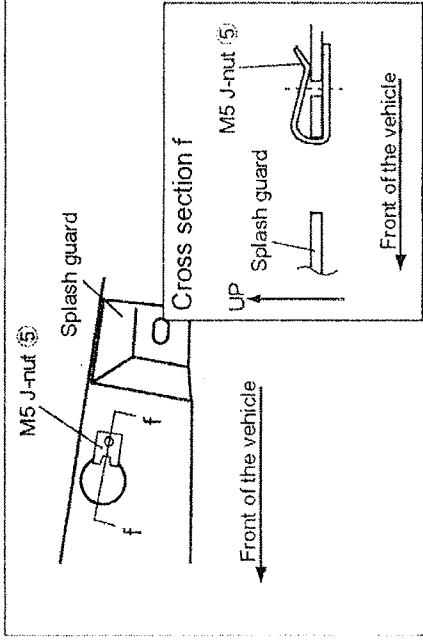

- (1) Insert M5 J-nut ⑤ into the hole of the splash guard in the procedure 11.-(1) as illustrated.

⚠ Caution

Be careful about the inserting direction of M5 J-nut ⑤.

13. Drilling at the wheel house side of the splash guard

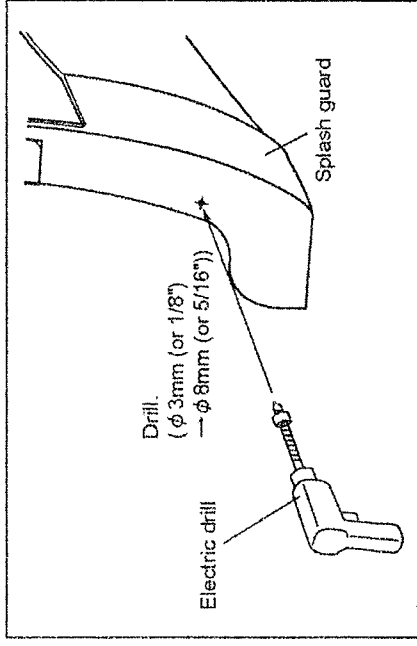

⚠ Caution: Important

Double check to confirm all hole center punch locations before drilling.

- (1) Use a $\phi 3\text{mm}$ (or $1/8''$) drill for a pilot hole at the punched position in the procedure 10.-(2) as illustrated. Use a $\phi 8\text{mm}$ (or $5/16''$) drill to open up the hole as illustrated.

14. Inserting M5 J-nut ⑤ into the hole of splash guard

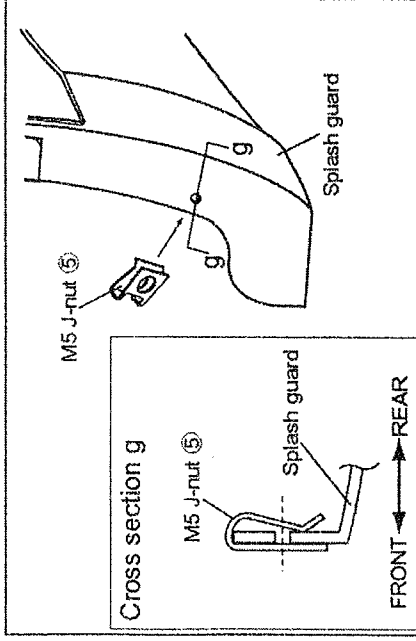

- (1) Insert M5 J-nut ⑤ into the hole of the splash guard in the procedure 13.-(1) as illustrated.

⚠ Caution

(2) Reinstall the splash guard into the vehicle.

Be careful about the inserting direction of M5 J-nut ⑤.

15. Inserting M5 J-nut ⑤ into the rear bumper

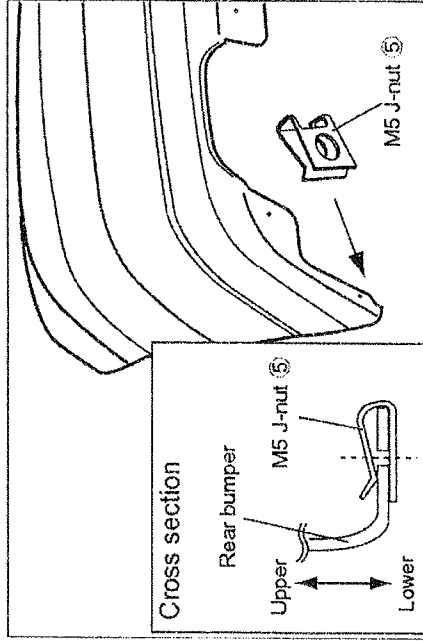

- (1) Insert M5 J-nut ⑤ into the rear bumper as illustrated. (1 location)

⚠ Caution

Be careful about the inserting direction of M5 J-nut ⑤.