

3. Cutting the Rear Deflector

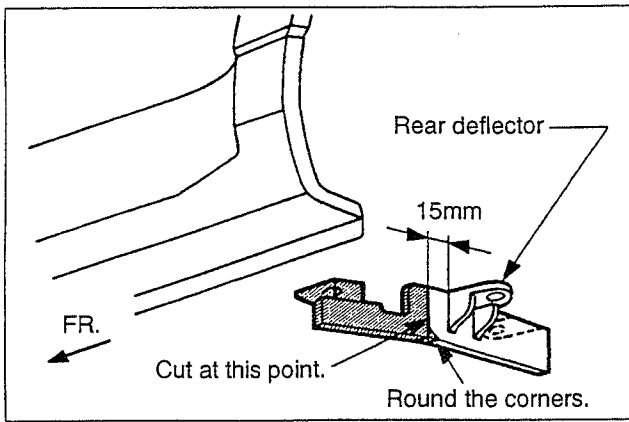

(1) Cut the rear deflector at a position 15mm towards the outside from the installing rib as shown in the diagram on the left. (Shaded section) Use scissors, etc. for the cut. Then round the corners.

* Detaching the rear deflector from the vehicle makes the procedure easier.

* If the rear deflector is detached, ensure that it is reattached again after cutting.

[9] Installation

1. Installing the Side Sill Protector

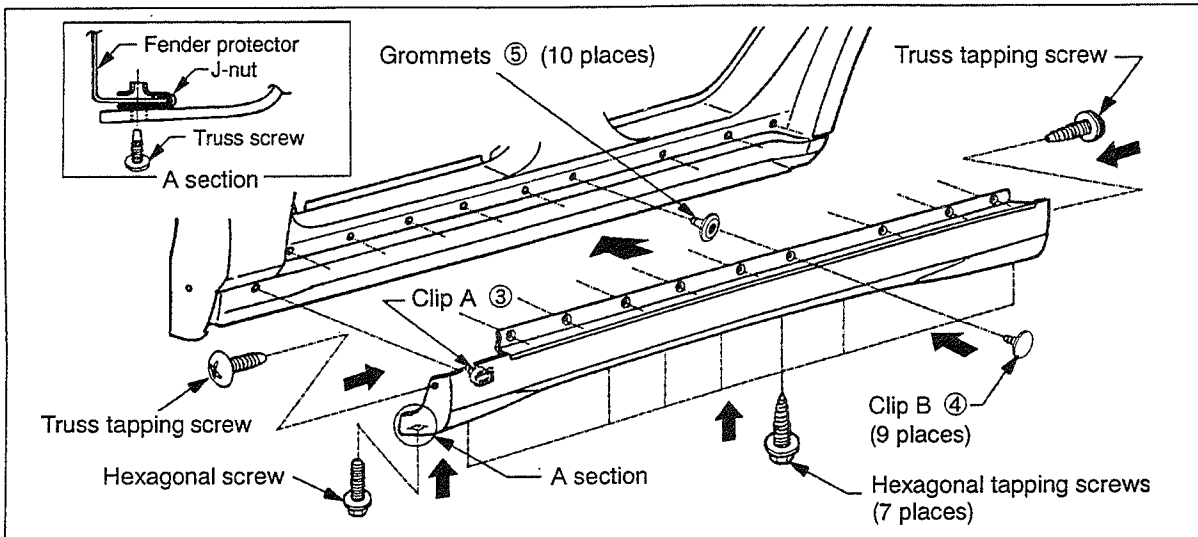

⚠ CAUTION

Ensure that the old grommets of the vehicle are replaced with the new grommets ⑤.

Failure to do so may result in the clips falling off.

- (1) Fit the side sill protector ① on the vehicle and push the clip A ③ (located on the back of the side sill protector) into the grommet on the vehicle.
- (2) Fit the installation holes (located on the side of the side sill protector) on the grommets of the vehicle and fix using the clip B ④. (9 places)
- (3) Hold the side sill protector ① so that there is no gap between the vehicle and the protector. Fasten the hexagonal tapping screws into the installation holes (located on the bottom surface of the side sill protector) from the front side (7 places) and fix the side sill protector. The hexagonal tapping screws were taken off in the procedure [8] -1. (1).
- (4) Fix the wheel housing section by fastening the truss tapping screws into the installation holes of the wheel housing section. (front and rear, 1 place each) The truss tapping screws were taken off in the procedure [8] -1. (1).
- (5) Fit the fender protector J-nut into the installation hole of the front bottom surface and fix using the hexagonal screw that was taken off in the procedure [8] -1. (1).